

Disclaimer

What's in the Box

Single Phase (AE1X0310)

Three Phase (AE1X0311)

Overview

Product Overview

Button Control

LED Indicator

Install the Smart Meter

Before Installation

Wiring Instructions

Mount the Smart Meter

Use the App

Download the Anker App

Add the Smart Meter

Select the Scene

Initialization Settings

CT (PV / ESS) Port Settings

Appendix 1: Wiring Diagrams for Special Scenarios

Appendix 2: Auto-Correction Function for Meter Wiring Errors

Appendix 3: Compatible Devices

Appendix 4: Specifications

Disclaimer

Please read and understand all safety instructions, installation guide, and other accompanied documents before installing or using the product. Failure to follow the instructions may result in electric shock, equipment damage, or personal injury. Please follow the instructions and install this equipment with caution for your safety and the normal operation of the product. The manufacturer is not liable for damage, injury, or loss resulting from incorrect installation, unauthorised modification, misuse, operation in unsuitable environments, or failure to observe safety precautions.

What's in the Box

Single Phase (AE1X0310)

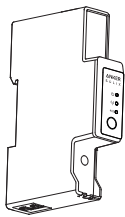

Anker SOLIX Smart Meter Gen 2 (Single-Phase)

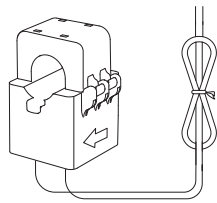

2x 63A Single CT Cable Assembly

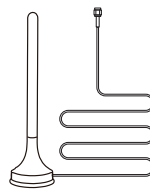

Extension Antenna

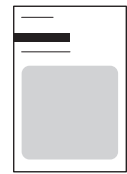

Document

Three Phase (AE1X0311)

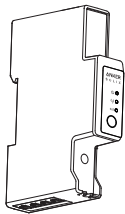

Anker SOLIX Smart Meter Gen 2 (Three-Phase)

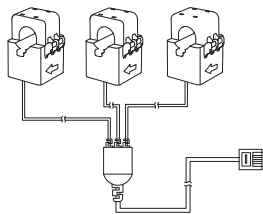

63A Three CT Cable Assembly

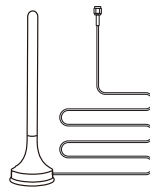

Extension Antenna

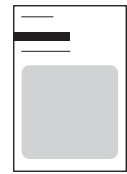

Document

Overview

Anker SOLIX Smart Meter Gen 2 is a DIN rail-mounted, compact smart meter that monitors voltage, current, and power in real time. It supports separate monitoring of household loads and photovoltaic (PV) system or energy storage system (ESS) for smart energy management and safe power use. The meter automatically corrects CT connections and can connect to the Anker app via Bluetooth or Wi-Fi, enabling remote control of operating modes and other functions.

Product Overview

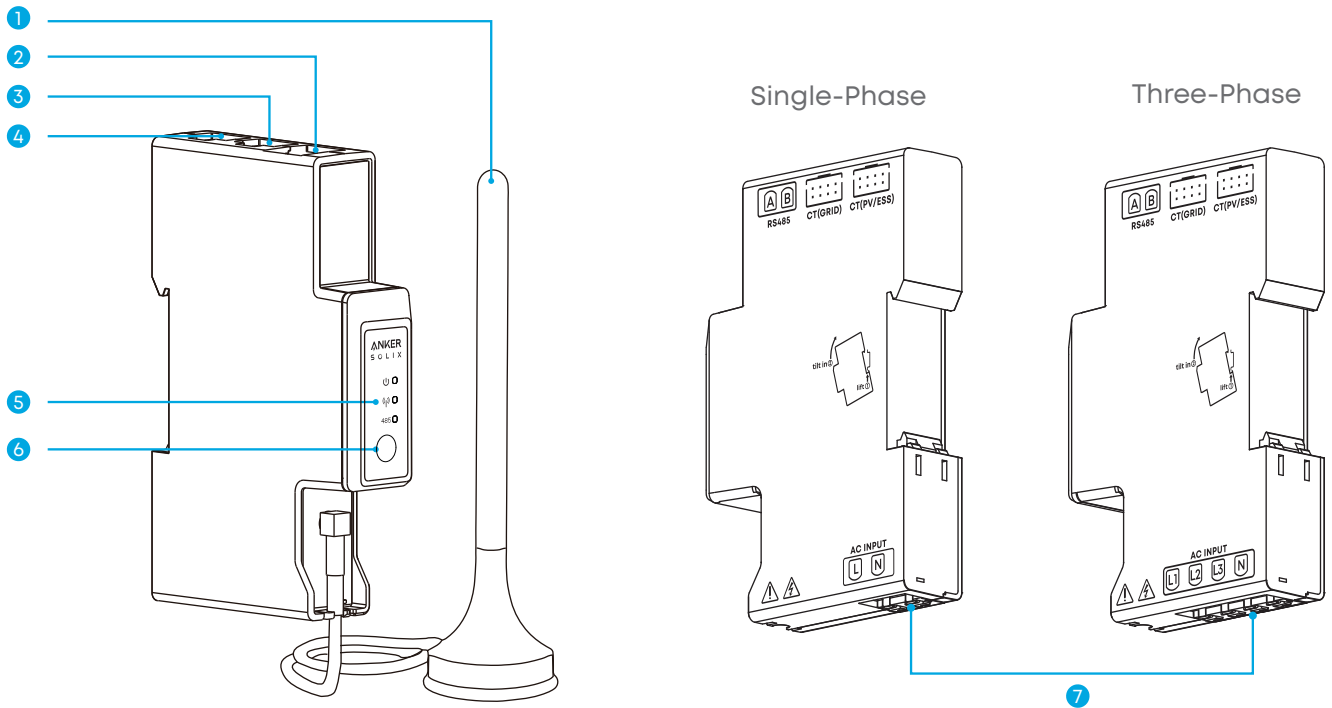

- 1 Antenna
- 2 RS485 Port
- 3 CT (Grid) Port
- 4 CT (PV / ESS) Port
- 5 LED Indicators
- 6 Main Button
- 7 AC Input Port





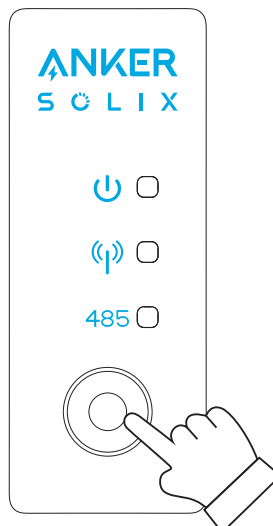

Button Control

Power On / Off: Press the main button for 2 seconds.

Reset IoT Connection: When the meter is powered on, press the main button for 7 seconds.

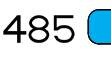

LED Indicator

| LED Indicator | Colour & State | Indication |
|---|--|---|
|  | Solid Blue | Working normally. |
|  | Flashing Red Slowly | No data collection or meter malfunctioning. |
|  | Solid Blue | Wi-Fi / Bluetooth connected. |
|  | Flashing Blue Slowly | No Wi-Fi / Bluetooth connected. |
|  | Flashing Blue Quickly | Confirming connection. |
|  | Solid Blue | RS485 port connected and communicated. |
|  | Flashing Red Slowly | RS485 port malfunctioning. |
|  | Indicator Lights Flashing from Top to Bottom | Firmware update in progress. |

Install the Smart Meter

Before Installation

1. Identify the entry phases. Under normal circumstances, the brown phase is live wire L1, the black phase is live wire L2, the gray phase is live wire L3, and the blue phase is the neutral wire N.

CAUTION: Always follow the phase sequence markings of the on-site electrical system during wiring. Wire color coding may vary by region, building, or installation period. Never determine phase sequence based on wire color alone.



| International Standard) New House - Common Scenarios | (Old German Standard) Old House - Rare Scenarios |
|--|--|
| Brown----Live Wire L1 | Red----Live Wire L1 |
| Black----Live Wire L2 | Yellow----Live Wire L2 |
| Gray----Live Wire L3 | Blue----Live Wire L3 |
| Blue----Neutral Wire N | Black----Neutral Wire N |
| Green and Yellow----GND PE | Green and Yellow----GND PE |

2. Prepare the corresponding color-coded voltage wires

Wiring Instructions



- Ensure the main breaker is turned off before wiring.
- Wear personal protective equipment before installing or operating the meter.

Connect the Voltage Wires

Connect the voltage wire from any unused circuit breaker slot to the corresponding hole on Smart Meter. The latch beneath the terminal will automatically pop up when the connection is successful.



- Pay attention to the AC input holes for the corresponding wires. Live and neutral wires must not be misconnected.
- This product is equipped with Weidmüller SNAP IN connection technology, providing fast, tool-free and secure wire connection.

Three-Phase

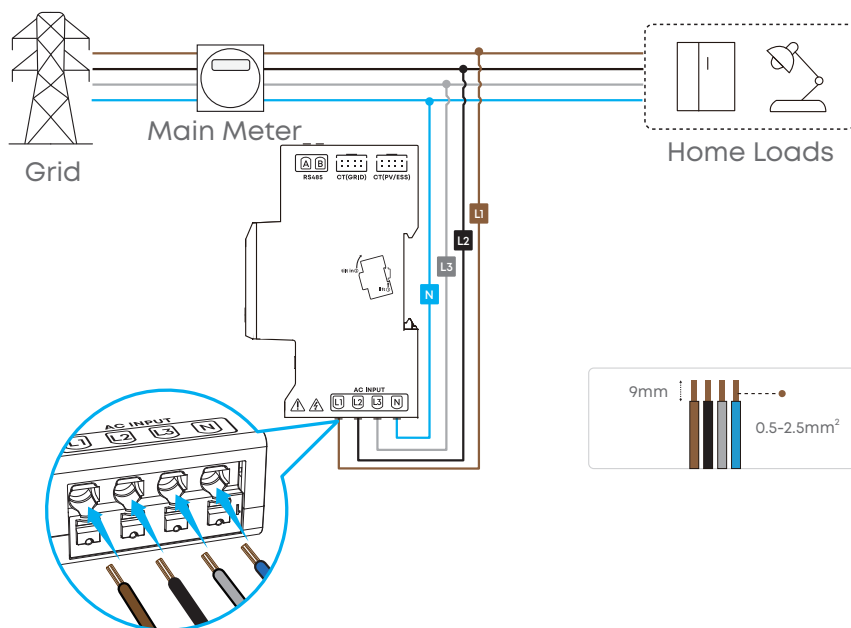

Single-Phase

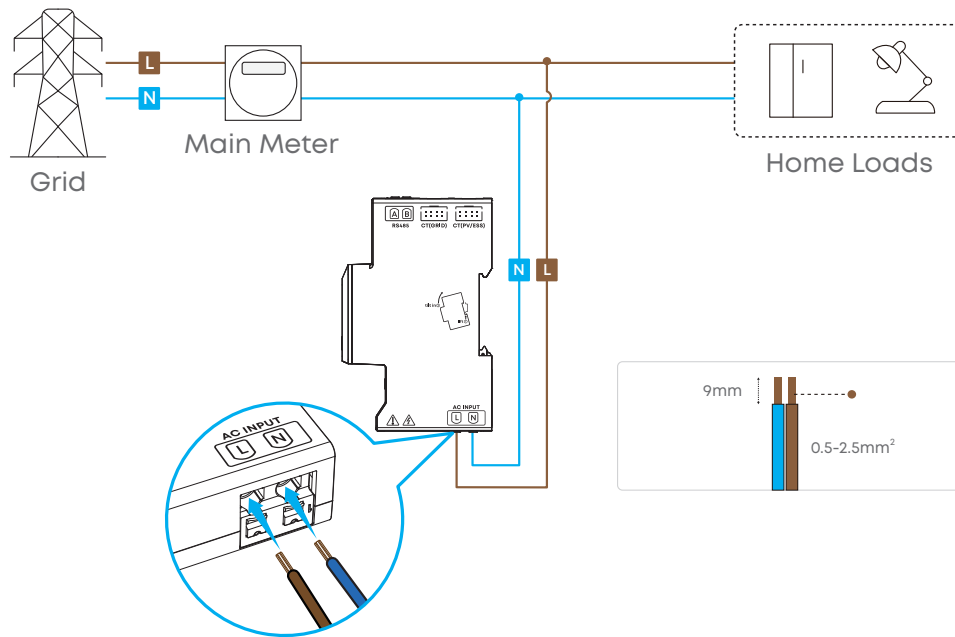

How to Disconnect the Wire (Optional)

Press down the raised green latch until you hear a click to disconnect the wires.

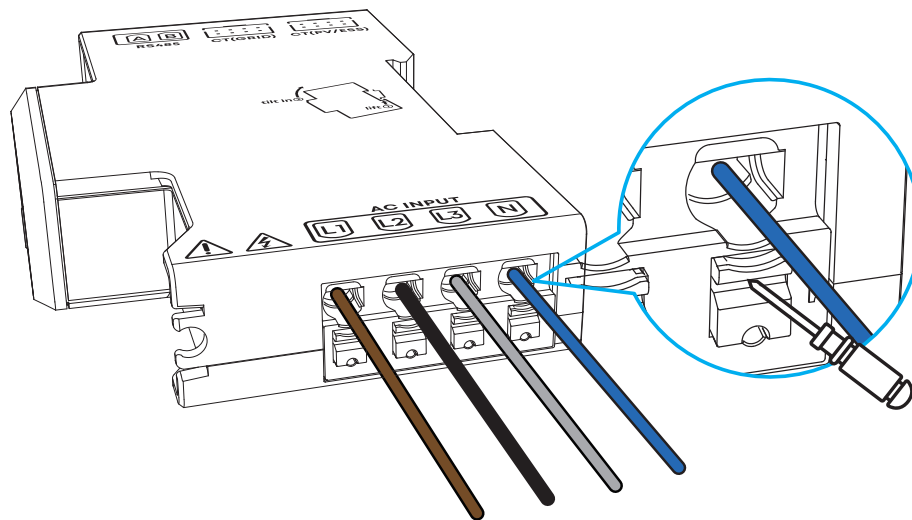

Connect the CT Cables

Connect to the CT (Grid) Port

Connect the CT cable to the CT (Grid) Port and snap the CTs onto the main live wires, as shown in the wiring diagram.

Note: Ensure the CTs are oriented in the correct direction of current:

- Snap L1 CT to L1 in the direction of current.
- Snap L2 CT to L2 in the direction of current.
- Snap L3 CT to L3 in the direction of current.

Three-Phase

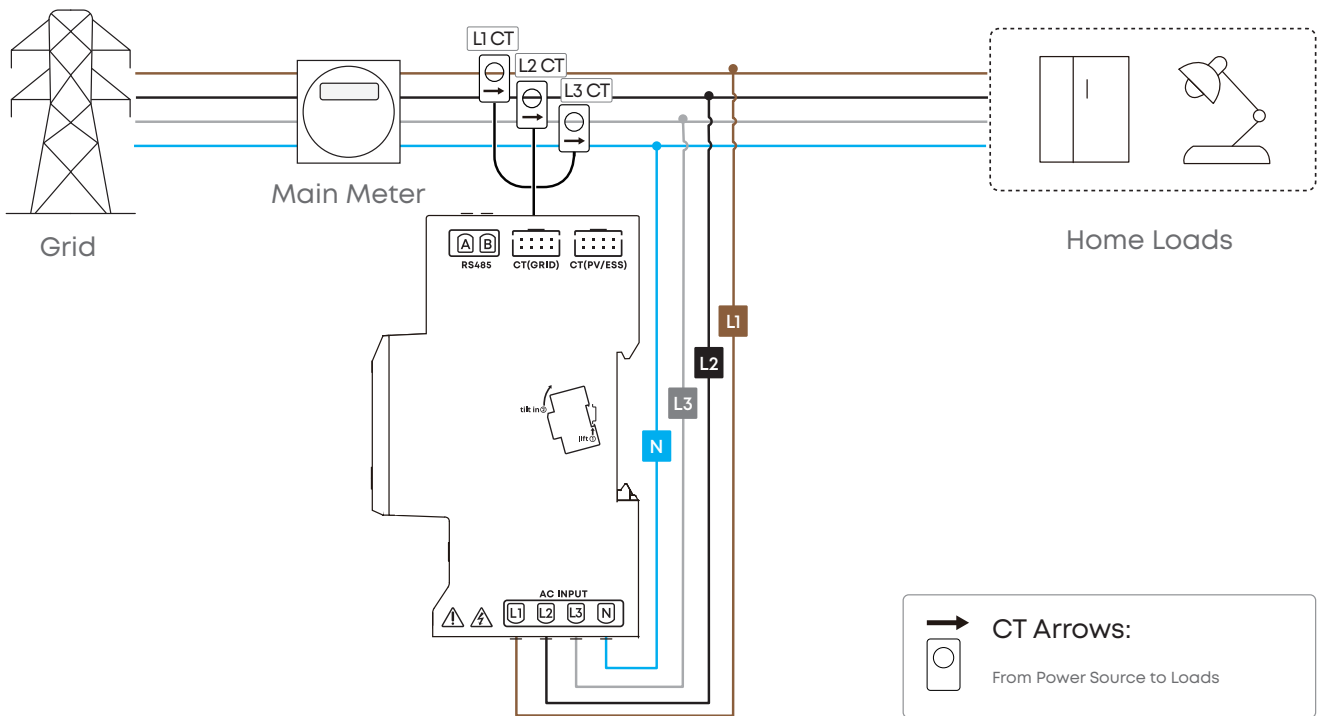

Single-Phase

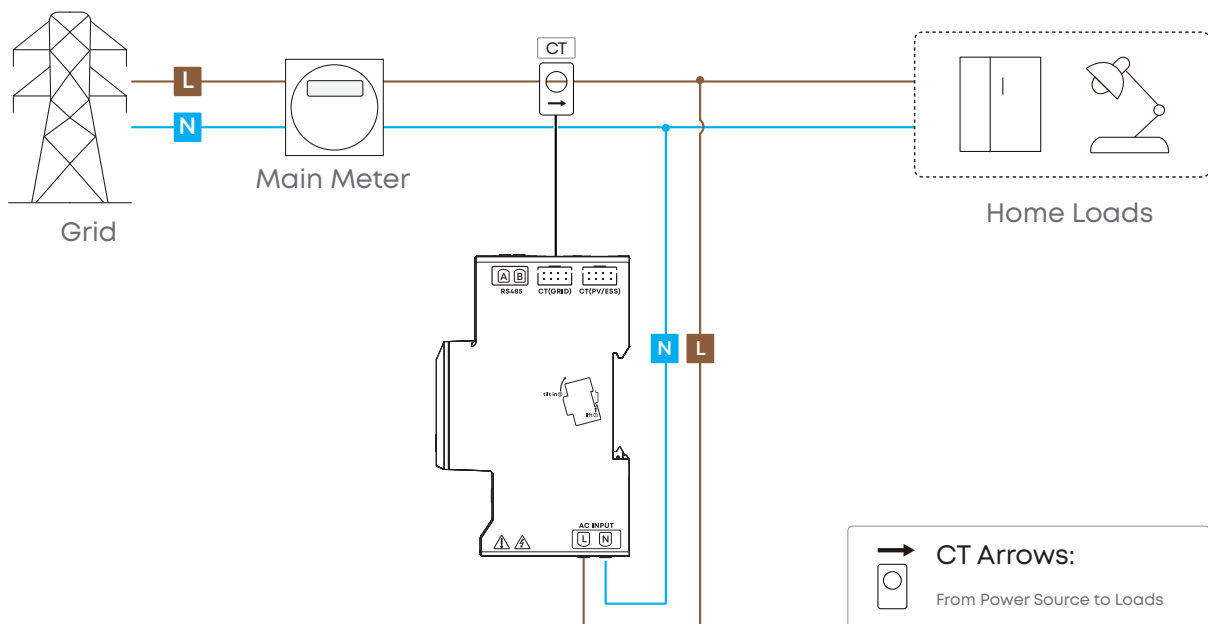

Connect to the CT (PV / ESS) Port (Optional)

Connect another CT cable to the CT (PV / ESS) Port and snap the CTs onto live wires of your PV system or energy storage system to monitor their energy independently.



To enable relevant functions when the CT (PV / ESS) Port is used to monitor a third-party PV system or Anker SOLIX energy storage system, refer to [CT \(PV / ESS\) Port Settings](#)

Scenario 1: Smart Meter for Existing Third-Party PV System

Three-Phase Grid System

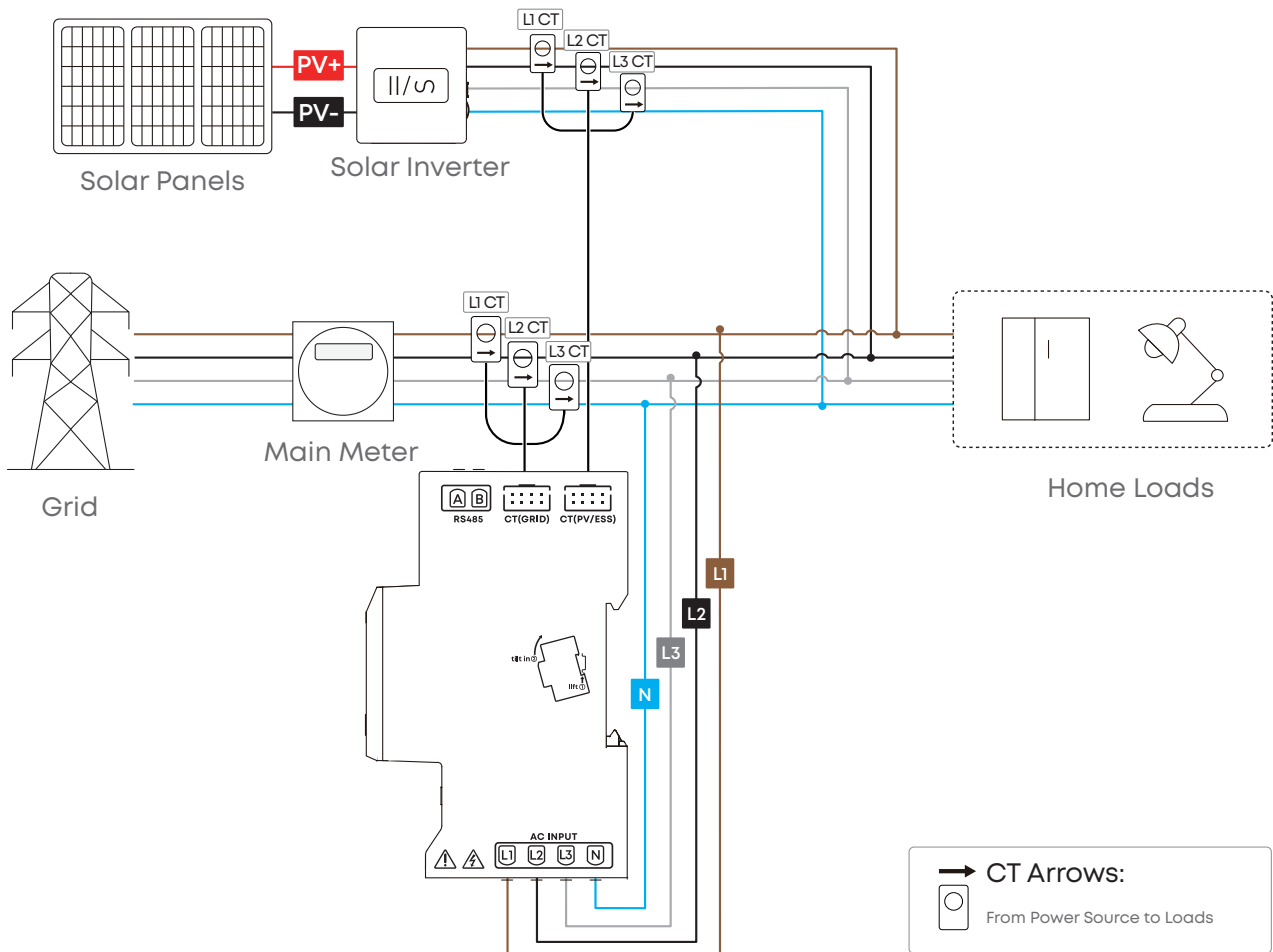

Single-Phase Grid System

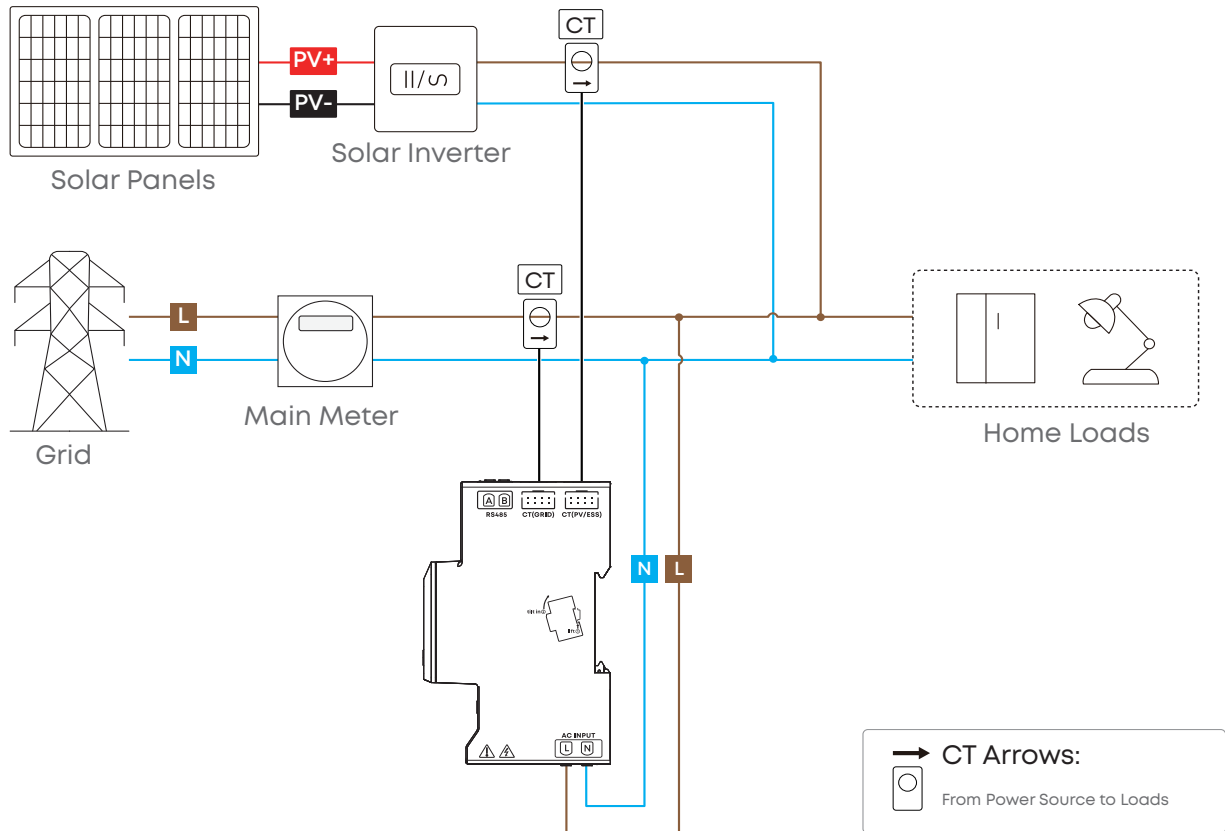

Scenario 2: Smart Meter for New Energy Storage System Three-Phase Grid System

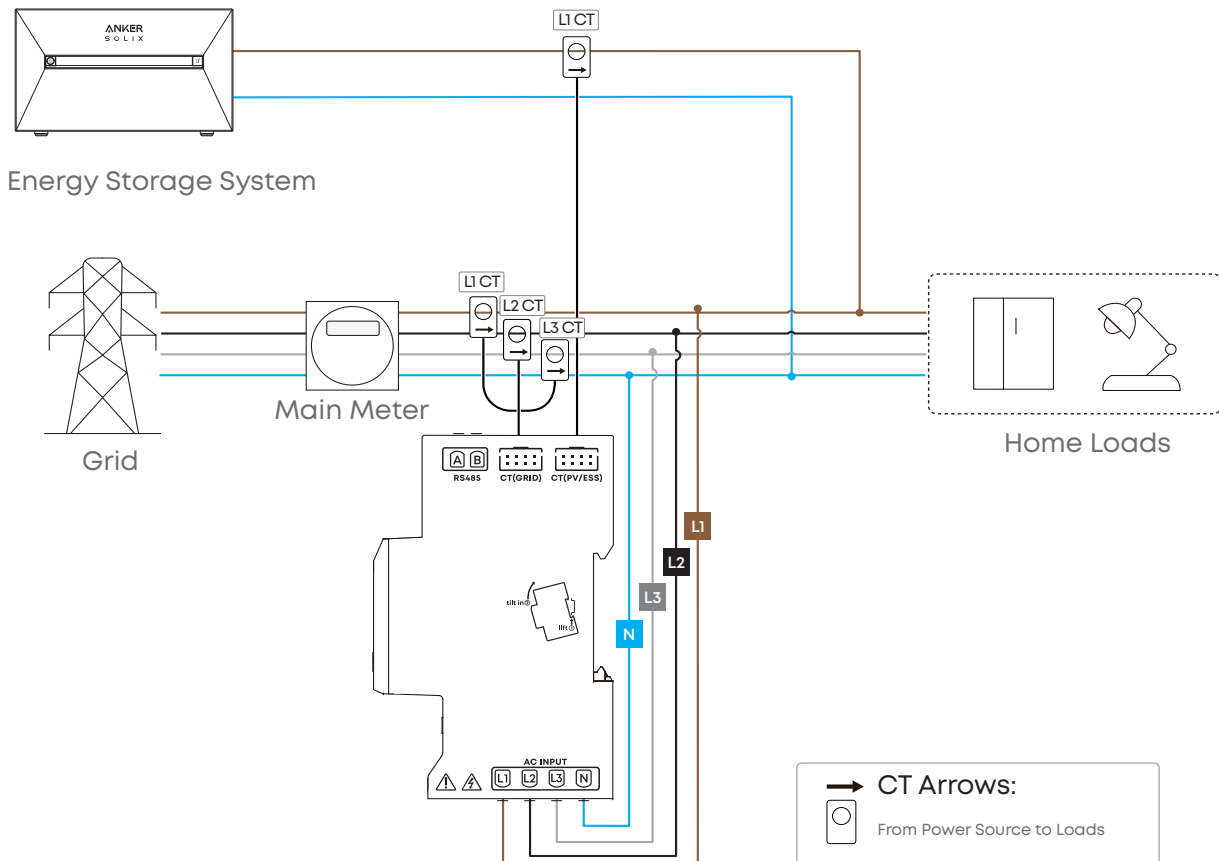

Single-Phase Grid System

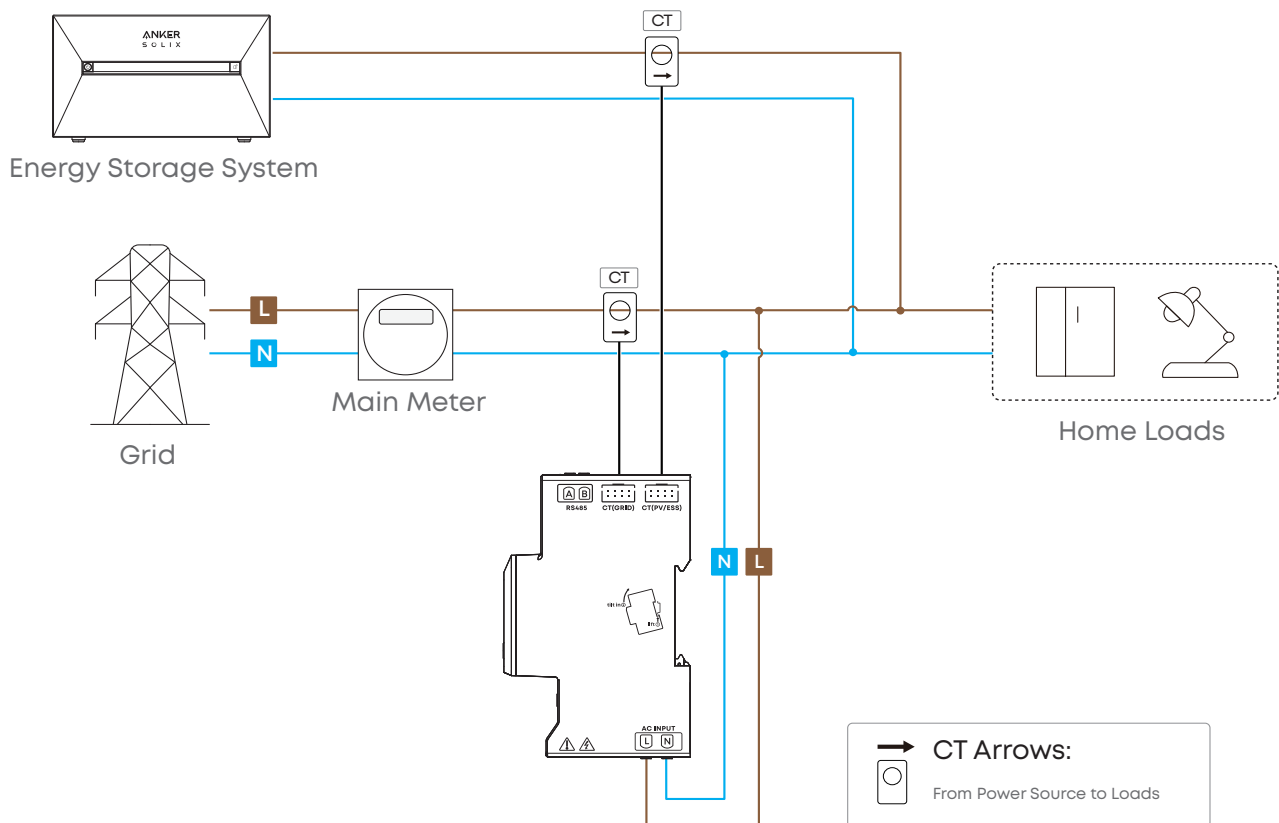

Connect the RS485 Cable (Optional)

If your energy storage system supports RS485, you can connect it to the meter via RS485 cable for a more stable connection and faster data response.

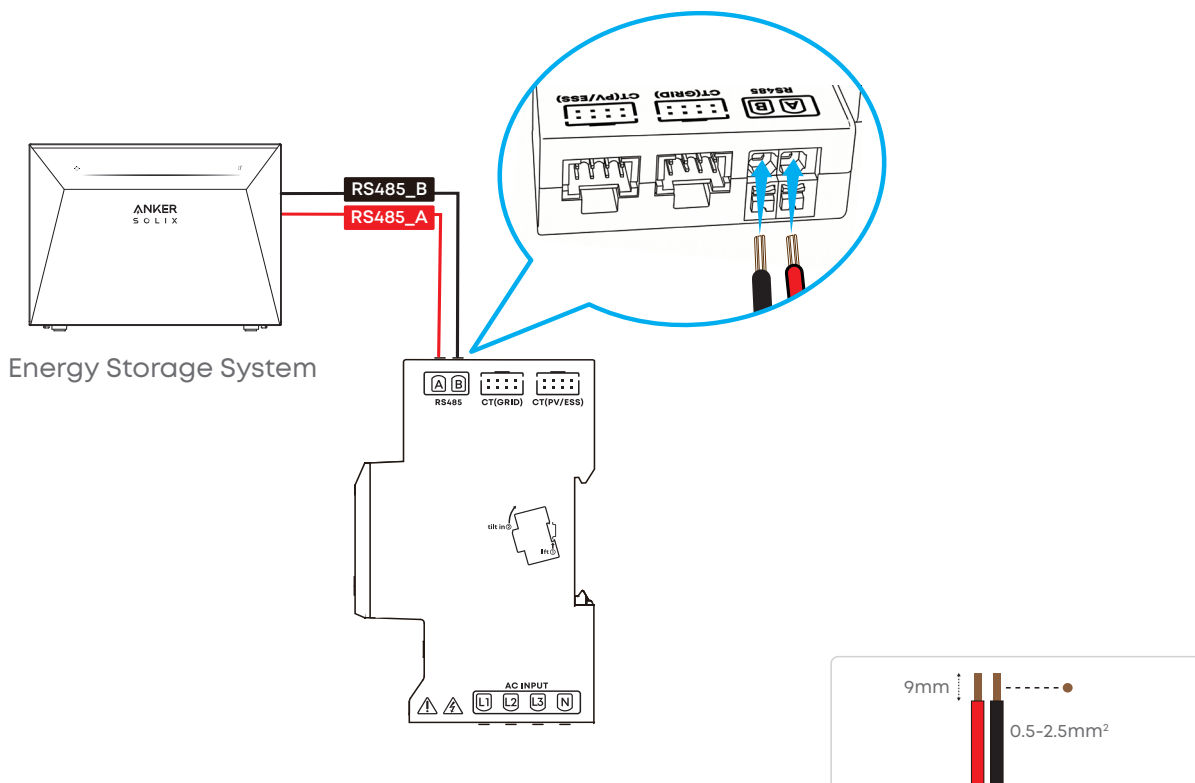

Mount the Smart Meter

1. After wiring, mount the Smart Meter onto the distribution box rail, ensuring it is securely fastened.

1

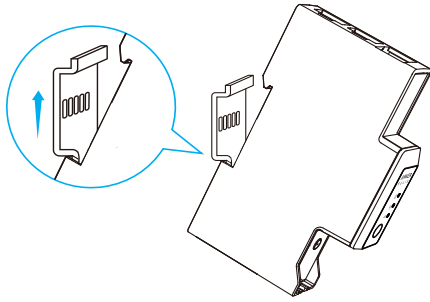

2

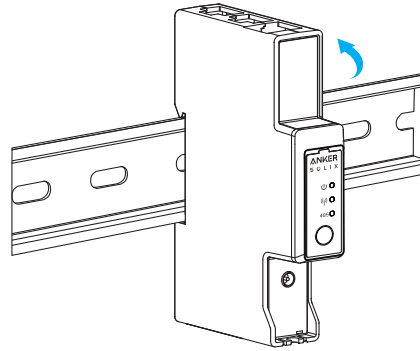

How to Unmount the Meter (Optional)

1

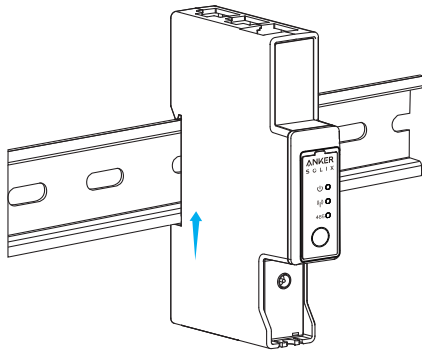

2

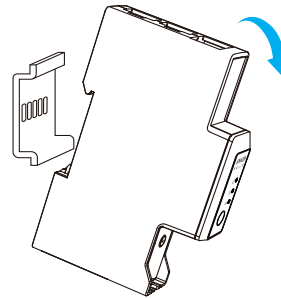

2. Plug in the antenna and then place the antenna on the distribution box.



Use the included 3M tape to mount the antenna to a non-metallic surface. Before applying the tape, confirm the mounting position and clean both the antenna base and distribution box surface. Once installed, do not remove and reapply the antenna.

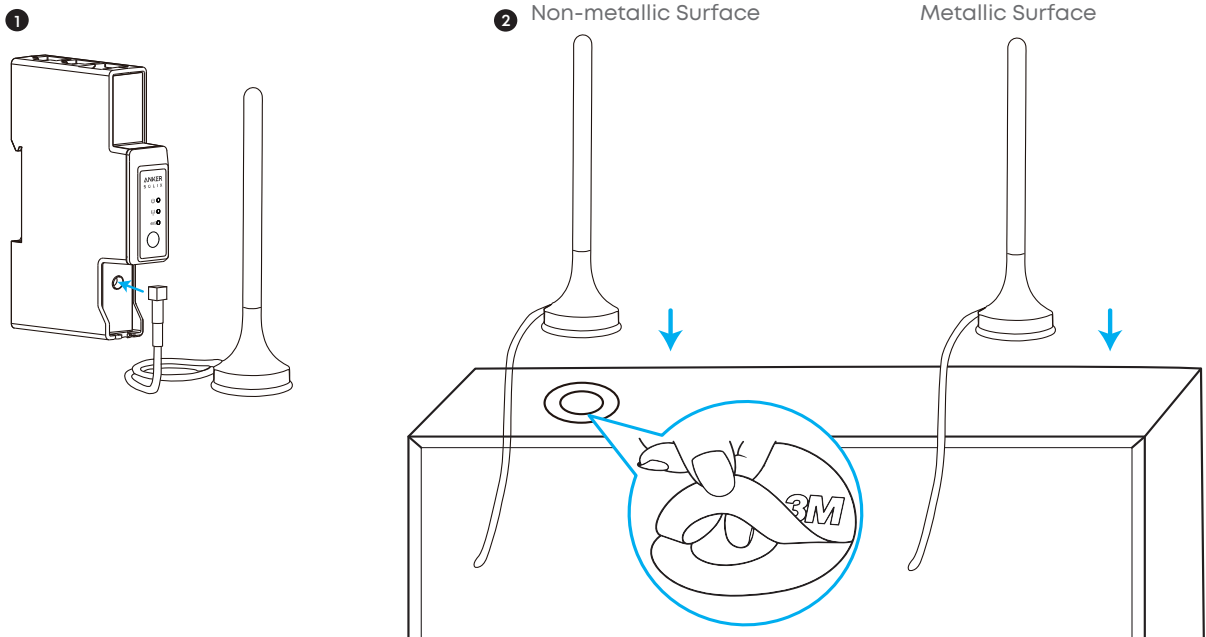

Use the App

Download the Anker App

Download the Anker app from the App Store (iOS devices) or Google Play (Android devices), or by scanning the QR code.

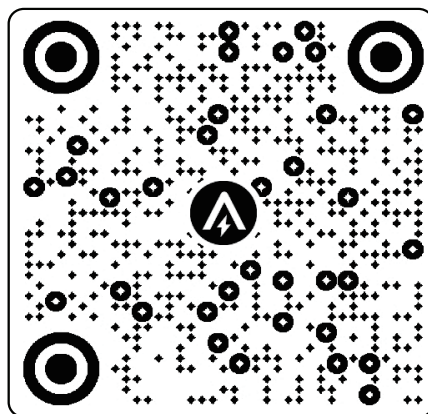

Google Play and the Google Play logo are trademarks of Google Inc.



Apple and the Apple logo are trademarks of Apple Inc.

Add the Smart Meter

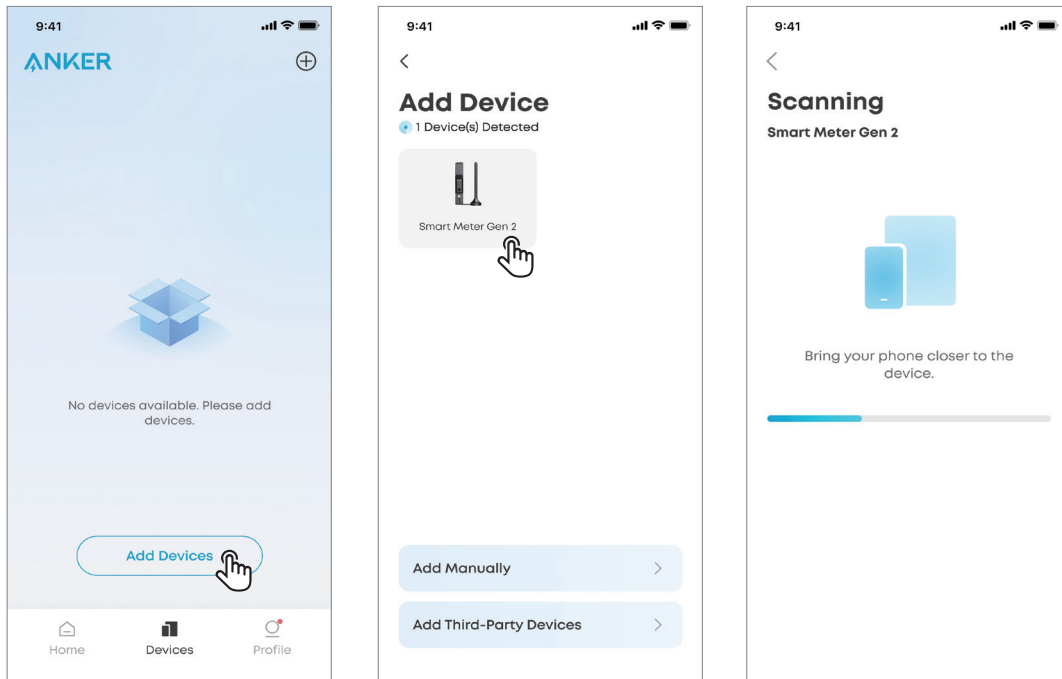

Select the Scene

Select **Build a Power System** or **Use Independently** according to the actual application scenario of the meter.

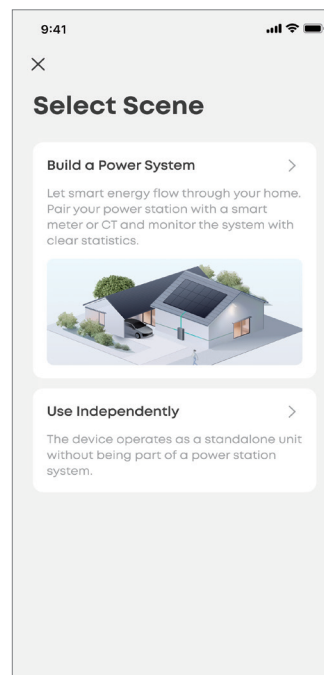

Initialization Settings

Due to different meter usage scenarios, the initialization settings procedure may differ. Please refer to the in-app instructions to complete the initialization settings.

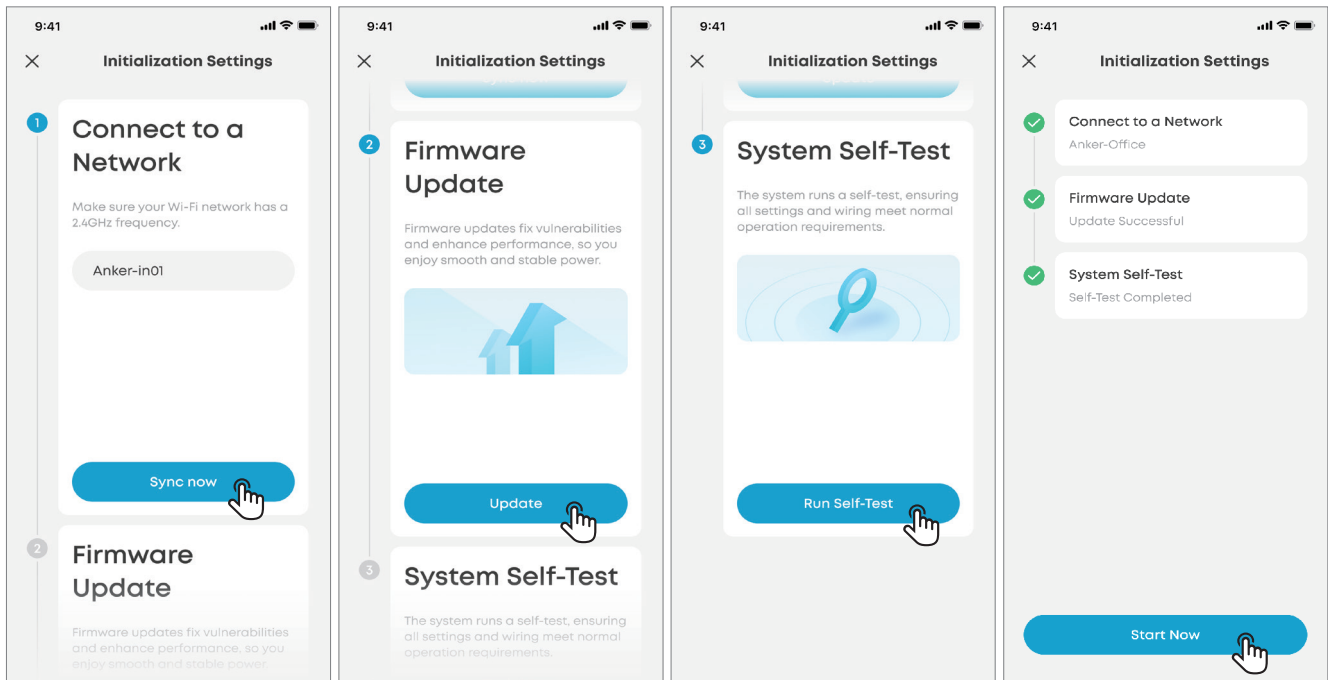

CT (PV / ESS) Port Settings

Monitor Third-Party PV System

Clamp the CT(s) onto the circuit of a third-party PV system to bring it into your Anker power station's energy monitoring and optimization.

How to enable:

Option 1: During initial system setup

If the CT(PV/ESS) port is already connected to the third-party PV system circuit before you setup:

1. During **System Configuration**, select **Third-Party Solar Power Systems**.
2. Select **a third-party PV system has been installed in my home**.
3. Select **Third-party PV system installed, can be monitored via CT** and tap **Save**.

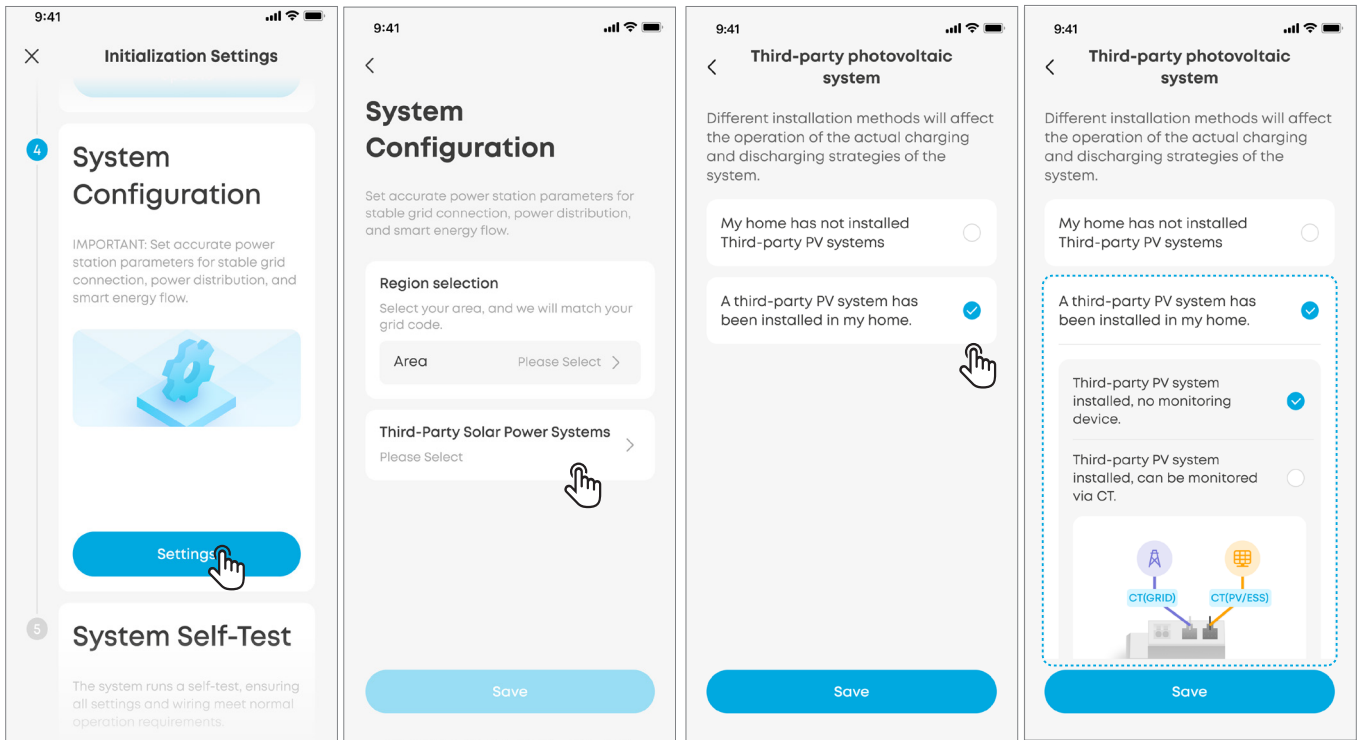

Option 2: After system setup is complete

If you connect the CT(PV/ESS) port to the third-party PV circuit later:

1. Go to **Settings** → **CT Monitoring Settings**.
2. Select **Third-party PV monitoring** and tap **Save**.

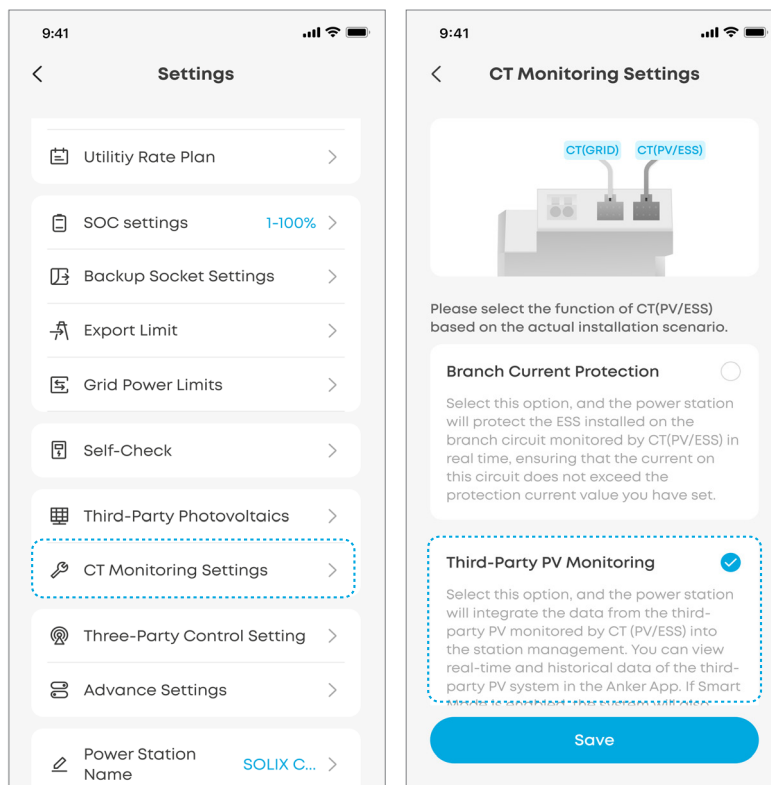

Monitor Energy Storage System

Clamp the CT(s) onto the circuit of a third-party PV system to bring it into your Anker power station's energy monitoring and optimization.

How to enable:

1. Go to **Settings** → **CT Monitoring Settings**.
2. Select **Branch protection current**.
3. Complete the circuit detection process.
4. Set the desired current protection threshold for that circuit.

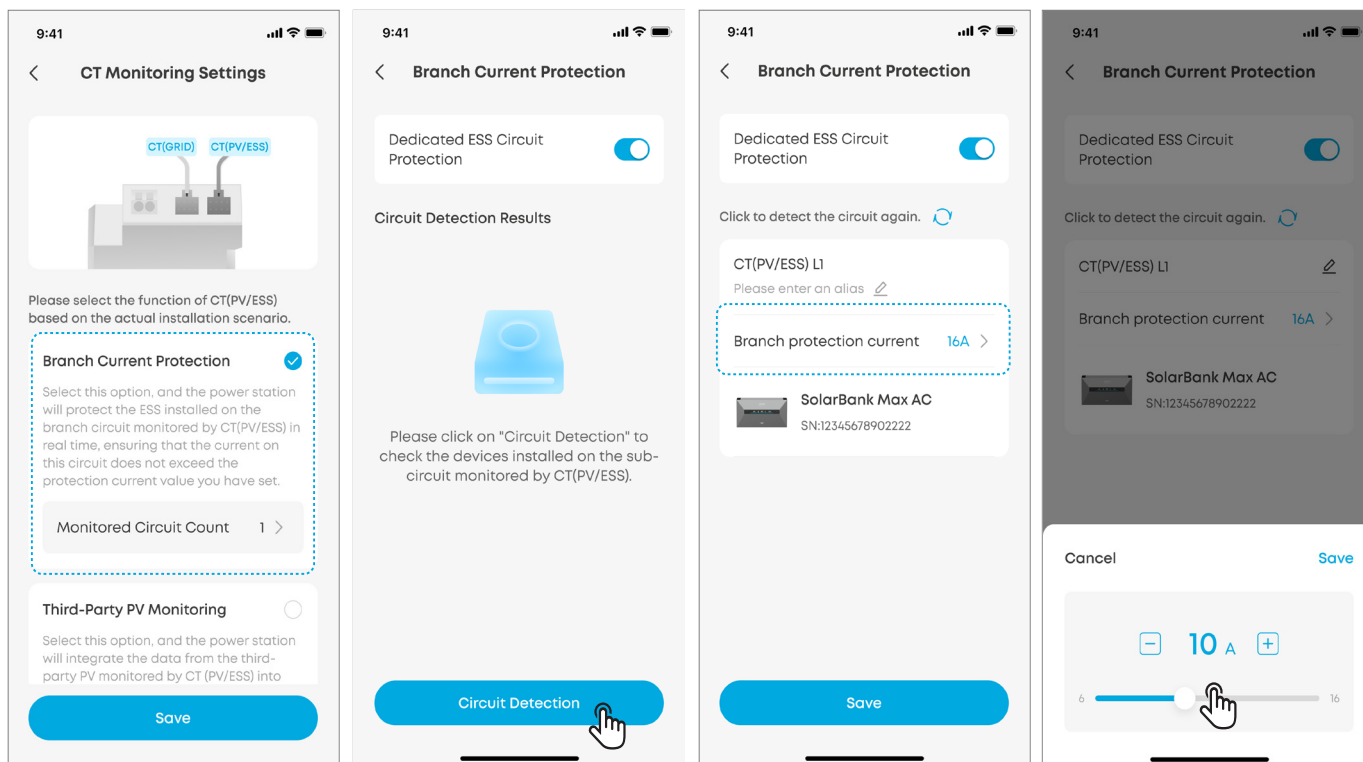

Appendix 1: Wiring Diagrams for Special Scenarios

Special Scenario 1: Third-Phase Smart Meter for Single-Phase Grid System

In this scenario, connect the grid's L wire to the meter's L1 terminal and snap CT1 (GRID) to the L wire. Otherwise, the meter may not function properly.

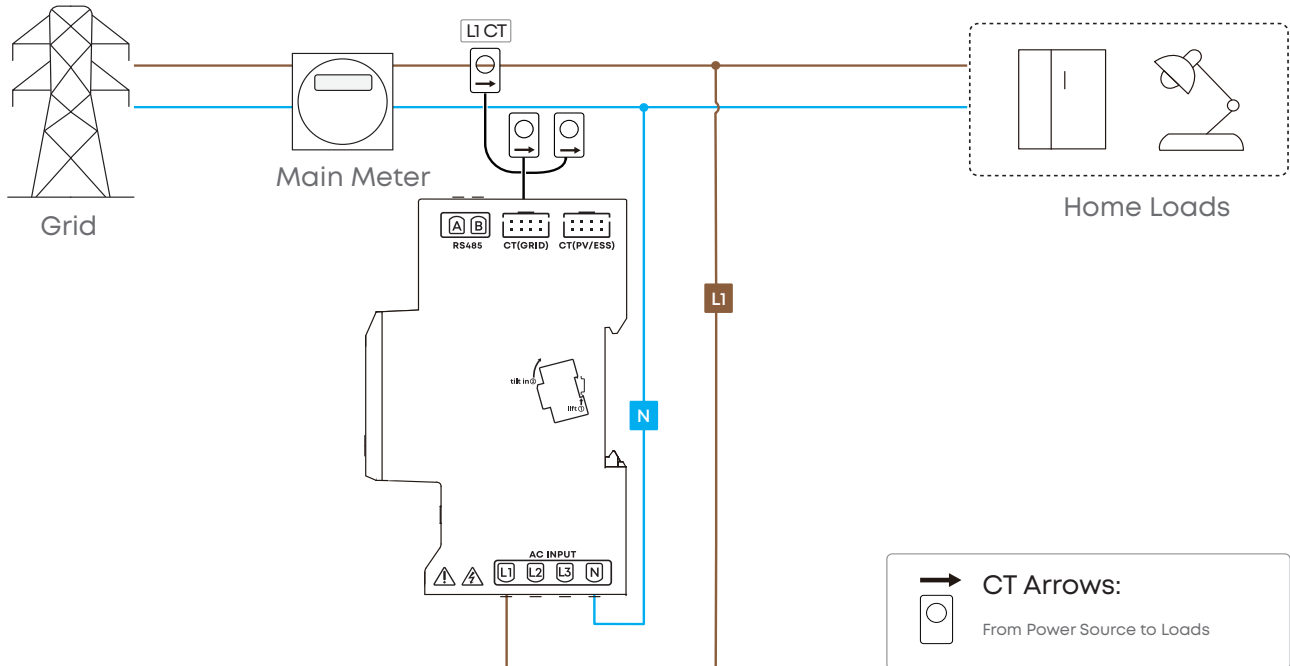

Special Scenario 2: Third-Phase Smart Meter for Three-Phase, Three-Wire (3P3W) System

For a three-phase meter used in a Three-Phase, Three-Wire (3P3W) System, connect the voltage wires as follows. Otherwise, the meter may not function properly.

| Grid | Smart Meter | |
|-----------|-------------------|-----------|
| Live Wire | AC Input Terminal | CT (Grid) |
| L1 | L1 Terminal | CT1 |
| L2 | N Terminal | / |
| L3 | L3 Terminal | CT3 |

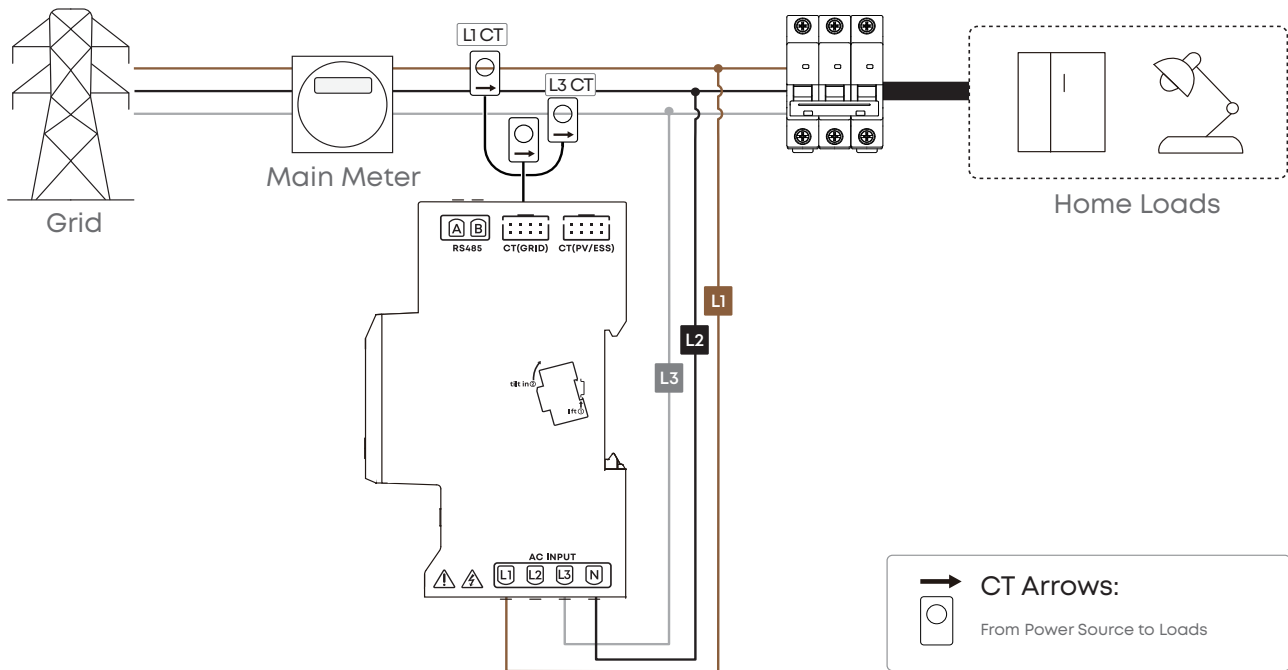

Appendix 2: Auto-Correction Function for Meter Wiring Errors

Anker SOLIX Smart Meter Gen 2 supports automatic detection and correction of certain wiring errors, such as phase mismatches in voltage wires or CT installation directions. However, this function has certain limitations:

1. Requires a compatible energy storage system:

Currently supported models: Anker SOLIX Solarbank 4 E5000 Pro and Anker SOLIX Solarbank Max AC.

2. Phase Error Auto-Correction:

① For both single-phase and three-phase smart meters, the meter's N terminal must be correctly connected to the grid's N line; otherwise, phase error detection and correction will not work.

② For three-phase smart meters, ensure one CT on each live wire. The other two phases (not connected to the energy storage system) must have detectable power (>100 W). Otherwise, the meter may fail to identify phase errors, causing system self-testing failure or data errors.

3. Reverse Connection Auto-Correction:

For three-phase meters, all three CTs must be installed in the same direction (e.g., all CTs on L1/L2/L3 reversed) for automatic correction. If CTs are installed in different directions, automatic correction cannot be applied.

4. Scenarios not supporting Auto-Correction:

The three-phase smart meter is used in a Three-Phase, Three-Wire (3P3W) System.

Appendix 3: Compatible Devices

| Product Number | Product Name |
|----------------|-----------------------------------|
| AE103 | Anker SOLIX Solarbank 4 E5000 Pro |
| A17E2 | Anker SOLIX Solarbank Max AC |

Appendix 4: Specifications

| Product Name | Anker SOLIX Smart Meter Gen 2 (Single-Phase) | Anker SOLIX Smart Meter Gen 2 (Three-Phase) |
|-----------------------------|--|--|
| Model | AE1X0310 | AE1X0311 |
| Dimensions (H×W×D): | 105*19*66.7 mm | 105*19*66.7 mm |
| AC Rated Input | 230Va.c., 50/60Hz, CT 40mA, 2W CAT III | 3~230/400Va.c., 50/60Hz, CT 40mA, 2W CAT III |
| Frequency | 50/60Hz | 50/60Hz |
| Max Measurement per Channel | 120A | 120A |
| Power Consumption | < 2 W | < 2 W |
| Ammeters Accuracy | ±1 % (1-120 A), ±2 % (<1 A) | ±1 % (1-120 A), ±2 % (<1 A) |
| Connection | Bluetooth, 2.4GHz Wi-Fi, RS485 | Bluetooth, 2.4GHz Wi-Fi, RS485 |
| DIN Rail | 35mm | 35mm |
| Protection Rating | IP20(Indoors Only) | IP20(Indoors Only) |
| Operating Temperature | -25°C to 55°C | -25°C to 55°C |
| Max. altitude | 2000m | 2000m |
| Warranty | 2 Years | 2 Years |
| Lifespan | 10 Years | 10 Years |
| Compatible CT | CT 63A(ø 10mm) CT 120A(ø 16mm) | CT 63A(ø 10mm) CT 120A(ø 16mm) |

Default Exposed Network Interfaces and Services

Bluetooth Low Energy (BLE) Status: When the equipment is not connected to a network, BLE broadcasting and BLE services are automatically enabled to provide Bluetooth network configuration capabilities.

Note: During the BLE configuration process, ensure your network environment is stable and follow the instructions to complete the setup.